

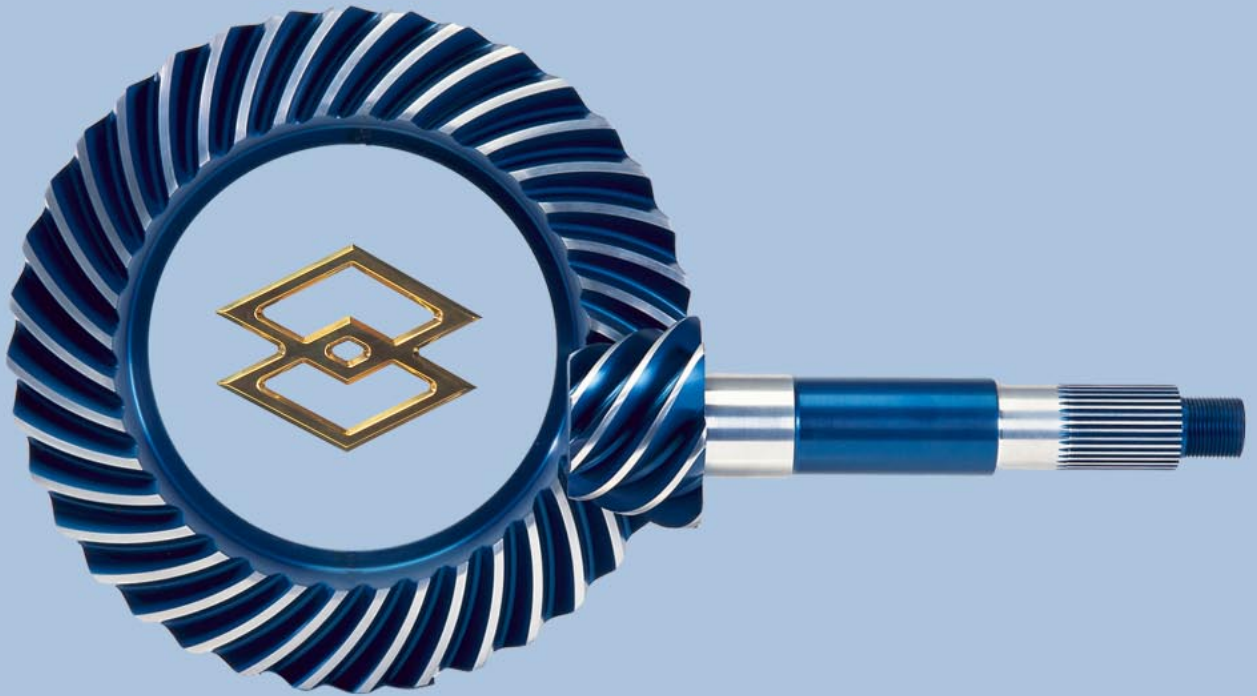

Winners Run RICHMOND!



**HI-PERFORMANCE RING & PINIONS
INSTALLATION INSTRUCTIONS**

**Made In The
U.S.A.**



A REGAL-BELOIT Company

RICHMOND GEAR INSTALLATION INSTRUCTION VIDEO

It is our strong recommendation that you read this set of instructions very carefully before beginning the actual gear set installation, since no gear set can be expected to withstand the abuse of performance applications if not carefully and properly installed. An extra ten minute at this point could spell the difference in regard to safety and extended gear life...or a prematurely failed gear set. Don't rush the installation! It can be a foolish waste of time.



The RICHMOND GEAR INSTALLATION INSTRUCTION VIDEO is designed for you to see how to properly install ring and pinion gear sets.

Applications covered in this video include:

American Motors • Chevrolet 10 bolt 1955-1964 • Chrysler 8.25" • Chrysler 8.75" and 9.25" • Corvette 1955-1962 • Corvette 1963 - present • Dana 28-44-60 • Ford 8"-8.8"-9"-



Location of backlash dimension & gear serial no. on ring gear

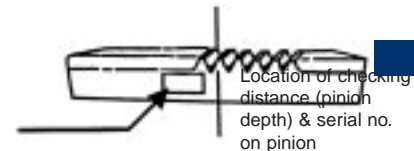

Location of checking distance (pinion depth) & serial no. on pinion

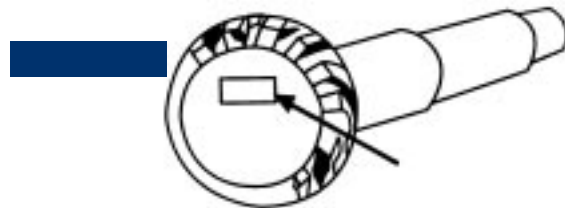

follows (see illustration A): Ref: BL.008, which means a backlash figure of .008 inch at the closest point. Pinion depth settings (or checking distance) are marked on the face of the pinion gear as follows (see illustration B): Ref: CD 2.799, which means distance of 2.799 inches from centerline of the ring gear to pinion face. Dimensional variations for backlash **SHOULD NOT EXCEED .004"** variation. **Example: If backlash is .008, the backlash -- including maximum variation -- should be .008-.012.** (Honda S2000 backlash settings is .006)

STEP 4. When installing the pinion gear you must check its depth in the housing as per the pinion depth dimension. Add or subtract pinion depth shims to arrive at the checking distance etched on the surface of the pinion face. (See illustration C.). Refer to Helpful Hints & Additions to Richmond Gear Installation Instructions on pages 3 and 4.

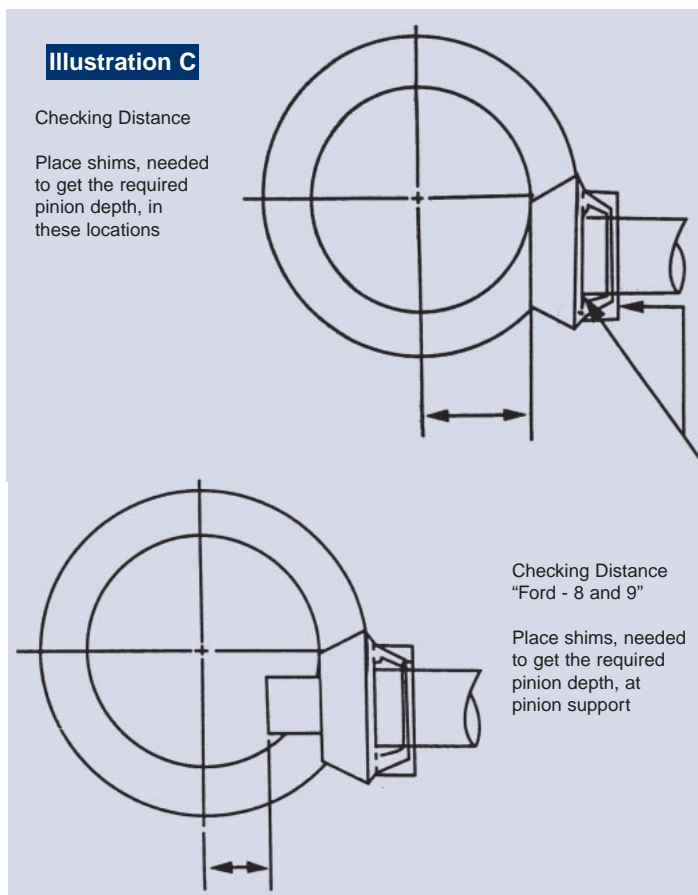

STEP 5. Using a mew crush collar or preload shim pack, set the pinion rotating torque to 10-15 (used bearings) 20-25 (new bearings) inch pounds. For oval track applications when not using a cooling pump, set at 16-17 inch pounds on new bearings and 10 inch pounds maximum on used bearings.

STEP 6. After correct installation of the pinion gear, position the ring gear and check for backlash. Mount a magnetic-base dial indicator on the axle housing in such a way that the indicator plunger will be moving in a line that is tangent to rotation of the ring gear. This will provide you with a backlash reading which should conform to the figure etched on the side of the ring gear. Again, maintain a tolerance of .004 variation. Example: If backlash is .008, the backlash - including maximum variation - should be .008-.012. (Backlash is always

measured in 3 or more places equally spaced around in the ring gear.) Note: For oval track racing set BL at approximately .012-.014 inches.

STEP 7. Compensation for variations in this setting can be made by side-adjustment of the ring gear. Adjusting rings or side-shim packs can be changed to bring the backlash and rotating torque figures into tolerance. (Use same torque on gear bearings as on pinion bearings.) You are now ready to check the tooth contact pattern to assure that no accidental departures from the factory-marked specifications have been made. Apply a thin coat of RICHMOND GEAR compound ("Part # 55-0001-1") on gear teeth for best results. Tooth contact patterns should comply with those shown on next page. (Note rounded or bullet nose shape at heel end of pattern on Gear drive sides). See page 4 for patterns and additional installation hints.

If the pattern is not in those approximate positions, reset the pinion depth and reset gear backlash until the patterns are closer to the above diagram. Pinion and/or gear should not be adjusted to try to achieve a deeper pattern. The length of the pattern may vary with the amount of the load applied during the check procedure.

If satisfactory pattern results cannot be obtained after a reasonable adjustment, return the gear set to RICHMOND GEAR for evaluation. An accurate evaluation can not be obtained on a used set.

STEP 8. Fill the gear case with sufficient amount of RICHMOND GEAR 75-140 Synthetic Gear Lube with GL 6 rating, or better and maintain the proper level at all times. Proper maintenance is a must to protect your safety and working life of your gear set. Check oil level between scheduled oil change to insure that proper oil level is maintained. Inspect vent plug to insure it is clean and operating. Inspect oil leakage, excessive heating, or any unusual noise or vibration. Note: For oval track racing, add 2 to 3 additional pts. gear lube.

RICHMOND GEAR OIL



75-140 Synthetic Oil.

GL6 with Limited Slip Additive
1 U.S. Quart / 0.946 Liter

FINAL RESULTS

Properly designed, manufactured, and maintained RICHMOND GEAR gears, correctly assembled by you in a clean rigid gear box, and operated with the proper lubricant, should result in safe and satisfactory performance. Be sure you select the proper application for your gear set.

Any questions concerning these installation instructions must be forwarded to us for clarification at the following address:

RICHMOND GEAR
P.O. Box 238, Old Norris Road
Liberty, South Carolina 29657
TechLine: 864-843-9275
Email: tech@richmondgear.com

WARRANTY

Warranty is limited to material and/or workmanship defect at time of shipment from the factory, and in no event shall seller have any liability for consequential damages of any kind resulting from a breach of this warranty. This warranty will be void on all products that show evidence of misapplication, improper installation, abuse, lack of proper maintenance, negligence, or alteration from original design. This warranty is in lieu of any other warranties, either express or implied, INCLUDING ANY IMPLIED WARRANTIES OF MERCHANTABILITY OF FITNESS FOR ANY PARTICULAR PURPOSE.

ADDITIONAL INFORMATION

Buyer shall be solely responsible for determining the adequacy of the product for any and all uses to which buyer shall apply the product. The application by buyer shall not be subject to any implied warranty of fitness for that particular purpose. The manufacturer makes no warranty or representations, expressed or implied, by operation of law or otherwise as to the merchantability or fitness for a particular purpose of the goods sold hereunder. Buyer acknowledges that it alone has determined that the goods purchased hereunder will suitably meet the requirements of their intended use. In no event will the manufacturer be liable for consequential, incidental or other damages.

These instructions do not purport to cover all details or variations in equipment, nor to provide for every possible contingency to be met in connection with selection, installation, operation, lubrication, and maintenance. Should further information be desired or should particular problems arise which are not covered sufficiently for the purchaser's purpose, the matter should be referred to RICHMOND GEAR.

BREAK IN

A new ring and pinion installation, especially a high numeric ratio with new bearings, can cause an excessive heat buildup in the rear end and cause softening of the gear teeth and bearings if a break in is not performed.

Street vehicles should be driven at normal street driving speed for approximately 10 miles, then stop and let cool for 30 minutes. Do this 2 to 3 times. Towing vehicles need approximately 200 to 300 miles of normal street driving before being used for towing.

On circle track race cars make approximately 6 to 8 laps at slow speed, then let cool for 30 minutes. Make 6 to 8 more laps at slow speed, then 2 to 3 laps at full speed, then let cool again for 30 minutes.

Drag cars need only an initial run-in since they are driven short distances and heat is not normally a problem with proper lube and backlash allowance.

NOTE: If after the above break in is performed, overheating of the rear end is suspected, repeat the final portion of the break in procedures.







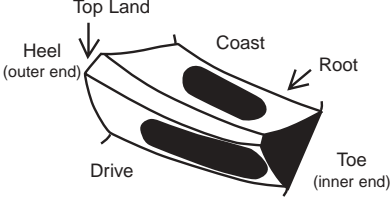

HELPFUL HINTS & ADDITIONS TO RICHMOND GEAR INSTALLATION INSTRUCTIONS

After completely reading instructions, go back to step #4. The following group of shim thickness are only if you do not have access to a pinion depth gauge or the old shim from the old pinion to start with. G.M.- .035, Ford 8-9" - .020, Ford 8.8 - 7.5 - .030, All Dana's- .035, 8-3/4 x 1-3/4 pin, - .090, 8-3/4 x 1-7/8 pin, - .020, Mopar- 9-1/4 - .020.

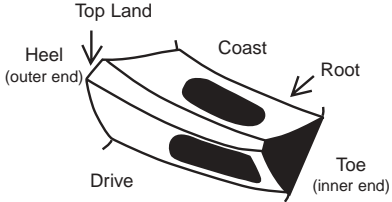
Pinion depth shims are located underneath the rear pinion bearing cone that is pressed on pinion with exception of the Dana Models. Dana pinion depth shims are underneath the rear pinion bearing cup in the housing. Dana carrier bearing preload shims are between carrier and bearing cone. All others are on the outside of bearing cup unless spanners are used as in the Ford 8 and 9 inch, both 8-3/4 and Mopar 9-1/4. Ford 8 and 9 inch pinion depth is regulated by shims between pinion support and chuck or center section.

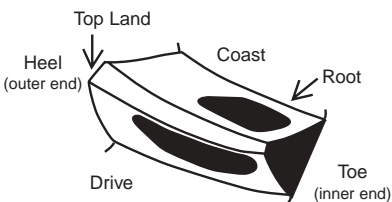
Step #5 - If crush collar is used to set bearing preload, do not use until you have established pinion depth and backlash and you are satisfied with the pattern you get. You can simulate pinion bearing preload by tightening pinion nut until the right preload is achieved with only motor oil on the pinion bearings. The crush collar and pinion seal should be last to install.

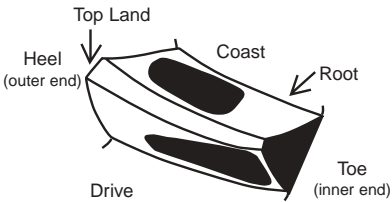
TOOTH CONTACT CHART

	Ring Gear Tooth Contact	Coast Side	Drive Side	Condition	Remedy
A		49-Series Ideal Pattern		IDEAL PATTERN (S2000)	V/A
					
B		69-79-Series Ideal Pattern		IDEAL PATTERN	N/A
					
C		All Series - Pattern Too High		HIGH TOOTH CONTACT heavy on the top of the drive gear tooth profile	Move the Drive PINION DEEP-ER into MESH.
					
D		All Series - Pattern Too Low		LOW TOOTH CONTACT heavy on the root of the drive gear tooth profile	Move the Drive PINION OUT of MESH.
					

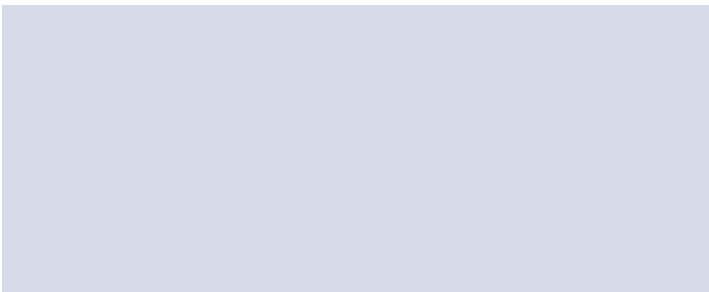

IMPORTANT INFORMATION



Please Read Carefully



The following ,  and  information is supplied to you for your protection and to provide you with many years of trouble free and safe operation of your Richmond Gear product.

Read **ALL** instructions prior to operating transmission and/or ring and pinion. Injury to personnel, transmission or ring and pinion failure may be caused by improper installation, maintenance or operation.



- **It is dangerous to get under a jacked-up vehicle.** The vehicle could slip off the jack and fall on you. You could be crushed. Never place any part of your body under a vehicle that is on a jack. Never start or run the engine while the vehicle is on a jack. **If you need to get under a raised vehicle, take it to a service center where it can be raised on a lift.**



- Hot oil can cause severe burns. Use extreme care when removing lubrication plugs and when working close to a unit that has been in operation.
- Check lube level between scheduled lube changes to insure that proper lube level is maintained. Inspect vent plug to insure it is clean and operating. Inspect the tightness of mounting bolts, misalignment of connecting shafts, lube leakage, excessive heating, or any unusual noise or vibration.
- Serious personal injury may occur as a result of improperly performed maintenance, adjustments or repairs.
- Do not attempt any of the maintenance, checks or repairs described on the following pages if you are not fully familiar with these or other procedures with respect to the transmission, or are uncertain as to how to proceed. Have the necessary work done by a properly equipped and qualified workshop.
- Always be extremely careful when working on the transmission. Always follow commonly accepted safety practices and general common sense. Never risk personal injury.



- Do not operate the transmission or ring and pinion without proper lube and correct amount.
- For safe operation and to maintain the unit warranty, when changing a factory installed fastener for any reason, it becomes the responsibility of the person making the change to properly account for fastener grade, thread engagement, load, tightening torque and the means of torque retention.
- Mounting bolts should be periodically checked to ensure that the unit is firmly anchored for proper operation.
- These instructions are not intended to cover all details or variations in equipment, nor provide for every possible contingency to be met in connection with selection, installation, operation, and maintenance. Should further information be desired or should particular problems arise which are not covered sufficiently for the Buyer's purpose, the matter should be referred to Richmond Gear.

In the event of the resale of any of the goods, in whatever form, Resellers/Buyers will include the following language in a conspicuous place and in a conspicuous manner in a written agreement covering such sale:

The manufacturer makes no warranties or representations, express or implied, by operation of law or otherwise, as to the merchantability or fitness for a particular purpose of the goods sold hereunder. Buyer acknowledges that it alone has determined that the goods purchased hereunder will suitably meet the requirements of their intended use. In no event will the manufacturer be liable for consequential, incidental or other damages. Even if the repair or replacement remedy shall be deemed to have failed of its essential purpose under Section 2-719 of the Uniform Commercial Code, the manufacturer shall have no liability to Buyer for consequential damages.

Resellers/Buyers agree to also include this entire document including the danger, warnings and cautions above in a conspicuous place and in a conspicuous manner in writing to instruct users on the safe usage of the product.

This information should be read together with all other printed information supplied by Richmond Gear.



A REGAL-BELOIT Company

1208 Old Norris Road • Liberty, SC 29657

Phone: 864-843-9231 • Fax: 864-843-2964 • www.richmondgear.com • Email: sales@richmondgear.com



TERMS & CONDITIONS

TERMS AND CONDITIONS OF SALES QUOTATIONS ARE MADE AND ORDERS ARE ACCEPTED BY SELLER SUBJECT ONLY TO THESE TERMS AND CONDITIONS:

1. **AGREEMENT AND MODIFICATION OF SALES TERMS.** The agreement between Seller and Buyer ("Sales Contract") is with respect to the sale of goods described on the other side hereof (the "goods"). Any Terms and Conditions contained in any purchase order or other form of communication from Seller's customers which are additional to or different from these Terms and Conditions shall be deemed rejected by Seller unless expressly accepted in writing by Seller.

2. **ACCEPTANCE OF ORDERS.** Acceptance by Seller of Buyer's purchase order(s) is expressly conditioned upon Buyer's assent to these Terms and Conditions. Buyer will be deemed to have assented to such Terms and Conditions unless Seller receives written notice of any objections within 10 days after Buyer's receipt of this form or in all events prior to any delivery or other performance by Seller of Buyer's order if less than 10 days.

3. **QUOTATIONS.** Quotations by Seller shall be deemed to be offers by Seller to sell the goods described therein subject to these Terms and Conditions, and acceptance of such offers is expressly limited to acceptance by Buyer of all of these Terms and Conditions within 30 days from the date of the quotation or as specified. Purchase orders submitted by Buyer for the goods quoted by Seller shall be subject to and will be deemed to constitute acceptance of these Terms and Conditions. All purchase orders will be subject to approval by Seller.

4. **TERMINATION OR MODIFICATION.** The Sales Contract may be modified or terminated only upon Seller's express written consent, which consent will at all times be conditioned on Buyer's agreement to pay Seller's modification or termination charge including, but not limited to expenses and costs plus a reasonable profit, except that any goods completed on or before Seller's acceptance of termination shall be accepted and paid in full by Buyer.

5. **PRICES AND TERMS.** Fulfillment of Buyer's order is contingent upon the availability of materials. The price of the goods sold pursuant to the Sales Contract shall be based upon Seller's prices in effect at the time of shipment and any acceptance of the order will be on the basis of the freight rates now in effect. In the event of an increase or decrease in the applicable freight charges before the material is shipped, such changes in freight charges will be for the account of Buyer. Price advances, discounts, extras and terms and conditions are subject to changes without notice. Unless otherwise provided on the front side hereof, price is F.O.B. Seller's point of shipment, and terms of payment shall be net 30 days from date of invoice. Seller may assess a delinquency charge of 1-1/2 percent per month on invoices not paid within stated payment terms. Seller may require full or partial payment or payment guarantees in advance of shipment whenever, in its opinion, the financial condition of Buyer so warrants. In addition, Seller may, at any time, suspend performance of any order or require payment in cash, security or other adequate assurance satisfactory to Seller when, in Seller's opinion, the financial condition of Buyer warrants such action.

6. **TAXES.** Prices do not include sales, use or other similar federal, state or local taxes. Buyer shall pay to Seller, in addition to the price of the goods, all applicable taxes which may be invoiced separately at a later date.

7. **DESIGN; EXTRA WORK; BUYER'S MATERIAL.** (a) If any order accepted by Seller contemplates the preparation of special designs by Seller, Buyer issuing such order will have a responsible representative specifically approve all designs prepared by Seller. (b) If Buyer requests extra work not included in the quotation or original order, Buyer will pay for the extra work at reasonable rates as determined by Seller. (c) In the event spoilage/damage occurs on orders where Buyer furnishes the material, Seller shall not be liable for replacement of or damage to such material.

8. **RISK OF LOSS, TITLE, SECURITY INTEREST.** Delivery shall occur, and risk of loss shall pass to Buyer, upon delivery of the material to a carrier at the F.O.B. point of shipment. Transportation shall be at Buyer's sole risk and expense, and any claims for losses or damage in transit shall be against the carrier only. However, Seller retains title to all products until paid for in full in cash and Buyer agrees to perform all acts necessary to provide a fully perfected security interest in the goods in favor of Seller. Seller may, at Seller's option, repossess the same, upon Buyer's default in payment hereunder, and charge Buyer with any deficiency.

9. **DELIVERIES AND QUANTITIES.** (a) Delivery dates are not guaranteed but are estimated on the basis of immediate receipt by Seller of all information to be furnished by Buyer and the absence of delay, direct or indirect, resulting from or contributed to by circumstances beyond Seller's reasonable control. If the goods are non-catalog goods, Seller may ship overages or underages to the extent of 10 percent of quantity ordered, and Buyer shall pay for such quantity based upon the unit price of the goods. Seller shall not be required to maintain closer control of quantity, unless specifically agreed to by Seller in writing. Quantities of all items may be determined by weight. Any claims for shortage must be within 10 days from the date of receipt of the goods by Buyer, and in every case the weights found in any particular shipment, including tare, must be given and Seller advised as to the method used by Buyer in computing the count of parts. (b) In the event that Buyer is unable to accept delivery of the goods at time of shipment, Seller shall invoice Buyer for the full purchase price as if shipment had been made and: (i) if Seller is able to store such goods in its own facilities, Buyer will pay Seller the reasonable handling and storage charges for the period of such storage, and (ii) if Seller is unable to store such goods at its own facility, Seller reserves the right to arrange handling and storage in a suitable bonded warehouse for the Buyer at Buyer's expense. In cases where handling and storage become necessary, it shall be Buyer's responsibility to notify Seller when shipment is to be made. Seller will make necessary arrangements for shipment at Buyer's expense.

10. **RETURNED GOODS.** Goods may not be returned. However, if Seller consents in writing or upon verbal authorization to the return of goods for any reason, transportation charges must be prepaid by Buyer, who also shall assume all risk of loss of such returned goods until actual receipt by Seller.

11. **INSPECTION, ACCEPTANCE.** Buyer shall inspect the goods immediately upon the receipt thereof. All claims by Buyer (including claims for shortages), except only those provided for under the WARRANTY AND LIMITATIONS OF LIABILITY and PATENTS clauses below, must be asserted in writing by Buyer within a 10 day period or they are waived. If this contract involves partial performances, all such claims must be asserted within a 10 day period for each partial performance. Rejection may be only for defects substantially impairing the value of products or work. Buyer's remedy for lessers defects shall be those provided for under the Warranty and Liability clauses. THERE SHALL BE NO REVOCATION OF ACCEPTANCE. If Buyer wrongfully rejects, revokes or delays acceptance of items or work tendered under this contract, or fails to make a payment due on or before delivery, or repudiates this contract, Seller shall, at its option, have a right to recover as damages, either the price as stated herein (upon recovery of the price, the items involved shall become the property of the Buyer) or the profit (including reasonable overhead) which the Seller would make from performance together with incidental damages and reasonable cost.

12. **WARRANTIES AND LIMITATIONS OF LIABILITY.** (a) Seller warrants to Buyer that the goods will conform to the following warranty: (i) for goods in Seller's Richmond Gear Hi Performance product line, the goods will be commercially free from defects in material and workmanship at the time of shipment of the goods by Seller; (ii) for goods in Seller's Ohio Gear, Electra Gear and Foote-Jones' product line, the goods will be commercially free from defect and workmanship upon normal use and service during the first 12 months of operation; a 6 month maximum shelf life is allowed; and (iii) for all other goods sold by Seller, the goods will be commercially free from defects in material and workmanship upon normal use for a period of 1 year from the date of shipment of the goods by Seller and will conform at the date of shipment to applicable specifications, drawings and blueprints, except for departures therefrom with written approval of Buyer; provided that work performed by Seller upon blanks and other materials furnished by Buyer is excluded from this warranty. Seller shall have no liability to Buyer for cost of blanks furnished by Buyer which are damaged or spoiled during heat treat or machining operations; (b) In the case of drives, gears and reducers manufactured by Seller, Seller warrants only that such products, when shipped, shall be capable of delivering the service rating as indicated in Seller's written documents, including quotations and catalogs or as noted on such products, providing such equipment is properly installed and maintained, correctly lubricated, operating under normal conditions with competent supervision, and within the load limits for which it was sold, and provided further that the equipment is free from critical speed, torsional or other type vibration, no matter how induced; (c) If any model or sample was provided to the Buyer, it was used merely to illustrate the general type and quality of goods and not to warrant that goods shipped would be of that type or quality; (d) UNLESS AUTHORIZED IN WRITING BY A CORPORATE OFFICER OR VICE PRESIDENT, NO AGENT, EMPLOYEE OR

REPRESENTATIVE OF SELLER HAS ANY AUTHORITY TO BIND SELLER TO ANY AFFIRMATION, REPRESENTATION OR WARRANTY CONCERNING THE GOODS SOLD UNDER THE SALES CONTRACT AND ANY SUCH AFFIRMATION, REPRESENTATION OR WARRANTY HAS NOT FORMED A PART OF THE BASIS OF THE BARGAIN AND SHALL BE UNENFORCEABLE; (e) Seller's sole obligation under the foregoing warranties is limited to either, at Seller's option, replacing or repairing defective goods (or defective parts thereof). This warranty does not cover the cost of installation of the new or repaired goods or parts. Replacement goods or parts are warranted for the remainder of the warranty period applicable to the goods originally supplied by Seller. All claims for allegedly defective goods must be made within 10 days after Buyer learns of such alleged defects. All claims not made in writing and received by Seller within such 10 day period shall be deemed waived. Buyer shall return a sample of the alleged defective part for Seller's inspection, and no other goods shall be returned to Seller without Seller's written consent. This warranty shall not extend to goods subjected to misuse, abuse, neglect, accident or improper installation or maintenance, incorrect lubrication, or goods which have been altered or repaired by anyone other than Seller or its authorized representative; (f) THE FOREGOING WARRANTIES ARE EXCLUSIVE AND IN LIEU OF ALL OTHER WARRANTIES OF MERCHANTABILITY, FITNESS FOR A PARTICULAR PURPOSE AND/OR ANY OTHER TYPE, WHETHER EXPRESS OR IMPLIED; (g) Products manufactured and work not performed by Seller are warranted only to the extent and in the manner that the same are warranted to Seller by Seller's vendors, and then only to the extent that Seller is reasonably able to enforce such warranty. In enforcing such warranty, it is understood Seller shall have no obligation to initiate litigation unless Buyer undertakes to pay all costs and expenses therefor, including but not limited to Attorney's fees, and indemnifies Seller against any liability to Seller's vendors arising out of such litigation; (h) THE FOREGOING IS SELLER'S ONLY OBLIGATION AND BUYER'S EXCLUSIVE REMEDY FOR BREACH OF WARRANTY, BUYER'S FAILURE TO SUBMIT A CLAIM AS PROVIDED ABOVE SHALL SPECIFICALLY WAIVE ALL CLAIMS FOR DAMAGES OR OTHER RELIEF INCLUDING BUT NOT LIMITED TO CLAIMS BASED ON LATENT DEFECTS. IN NO EVENT SHALL BUYER BE ENTITLED TO INCIDENTAL, CONSEQUENTIAL, OR SPECIAL DAMAGES, NOR SHALL SELLER'S LIABILITY EXCEED THE PURCHASE PRICE OF THE GOODS. EVEN IF THE REPAIR OR REPLACEMENT REMEDY SHALL BE DEEMED TO HAVE FAILED OF ITS ESSENTIAL PURPOSE UNDER SECTION 2-719 OF THE UNIFORM COMMERCIAL CODE, THE MANUFACTURER SHALL HAVE NO LIABILITY TO BUYER FOR CONSEQUENTIAL DAMAGES. ANY ACTION ARISING HEREUNDER OR RELATED HERETO MUST BE COMMENCED WITHIN ONE (1) YEAR AFTER THE CAUSE OF ACTION OCCURS OR IT SHALL BE BARRED, NOTWITHSTANDING ANY STATUTORY PERIOD OF LIMITATIONS TO THE CONTRARY; and (i) In the event of the resale of any of the goods, in whatever form, Buyer will include the following language in a conspicuous place and in a conspicuous manner in a written agreement covering such resale: "THE MANUFACTURER MAKES NO WARRANTIES OR REPRESENTATIONS, EXPRESS OR IMPLIED, BY OPERATION OF LAW OR OTHERWISE, AS TO THE MERCHANTABILITY OR FITNESS FOR A PARTICULAR PURPOSE OF THE GOODS SOLD HEREUNDER. BUYER ACKNOWLEDGES THAT IT ALONE HAS DETERMINED THAT THE GOODS PURCHASED HEREUNDER WILL SUITABLY MEET THE REQUIREMENTS OF THEIR INTENDED USE. IN NO EVENT WILL MANUFACTURER BE LIABLE FOR CONSEQUENTIAL, INCIDENTAL OR OTHER DAMAGES."

13. **REMEDIES AND LIMITATIONS OF LIABILITY.** In the event Buyer claims Seller has breached any of its obligations under the Sales Contract, whether of warranty or otherwise, Seller may request the return of goods and tender to Buyer, at Seller's option, a replacement shipment of goods. If Seller so requests the return of the goods, the goods will be redelivered to Seller in accordance with Seller's instructions and at Buyer's expense. Except as herein provided, Seller shall have no further obligation under the Sales Contract. The remedies contained in this paragraph and paragraph 12 hereof shall constitute the sole recourse of Buyer against Seller for breach of any of Seller's obligations under the Sales Contract, whether warranty or otherwise.

14. **TECHNICAL ADVICE.** Any technical advice furnished or recommendation made by Seller or any representative of Seller concerning any use or application of any of the goods is believed to be reliable, but SELLER MAKES NO WARRANTY, EXPRESSED OR IMPLIED, ON RESULTS TO BE OBTAINED. BUYER ASSUMES ALL RESPONSIBILITY FOR LOSS OR DAMAGE RESULTING FROM THE HANDLING OR USE OF ANY OF THE GOODS.

15. **FORCE MAJEURE.** Seller shall not be liable for failure to perform its obligations under the Sales Contract in whole or in part caused by the occurrence of any contingencies beyond the reasonable control either of Seller or of suppliers of Seller. If any such contingency occurs, Seller may allocate goods and deliveries among Seller's customers.

16. **ASSIGNMENT AND DELEGATION.** No right or interest in the Sales Contract shall be assigned by Buyer without Seller's prior written consent, and no delegation of any obligation owed, or to the performance of any obligation by Buyer shall be made without Seller's prior written consent. Any attempt at assignment or delegation shall be wholly void and totally ineffective for all purposes unless made in conformity with this paragraph.

17. **PATTERNS AND TOOLING.** Unless otherwise agreed to in writing with Buyer, Seller shall retain title to and possession of all special tooling, patterns and dies whether paid for by Buyer or not, but such special tooling, patterns and dies that are specifically paid for by Buyer will be held by Seller exclusively for the manufacture of Buyer's goods for not more than 2 years after the date of Buyer's last order requiring their use. Seller will exercise reasonable care in handling and storing any tooling, patterns or dies specifically paid for by Buyer, but Seller shall not be liable for damage or loss thereof.

18. **PATENTS.** SELLER MAKES NO REPRESENTATION OR WARRANTY WITH RESPECT TO THE PATENTABILITY OF THE GOODS OR THAT ANY OF THE GOODS WILL BE FREE FROM CLAIMS OF INFRINGEMENT. Buyer agrees to indemnify and defend Seller in any such suit, action or proceeding for any claim resulting from actual or alleged infringement of any domestic or foreign letters patent for (i) any feature, construction or design incorporated at Buyer's request in any goods or to adapt such goods to the particular use of Buyer or Buyer's customers or (ii) any additions, changes or adaptations made by Buyer or Buyer's customers after delivery of the goods.

19. **CONFIDENTIAL INFORMATION.** All drawings, diagrams, specifications, technical data and other materials furnished by Seller and identified by Seller as confidential are and shall remain the exclusive property of Seller and shall be returned to Seller upon request. Buyer agrees to treat such information and material as confidential and not to reproduce or disclose such information or materials without Seller's prior written consent. This paragraph does not apply to any information already known to and readily accessible in the trade or which may become so through no fault of Buyer.

20. **CHANGES.** Seller may, at any time, without notice, make changes (whether in design, material, improvements or otherwise) in any catalog goods, and may discontinue the manufacture of any catalog goods, all in its sole discretion, without incurring any obligations of any kind as a result thereof, whether for failure to fill an order of Buyer or otherwise.

21. **INSTALLATION.** Installation of the goods shall be by Buyer unless otherwise specifically stated in the Sales Contract.

22. **SEVERABILITY.** If any term or provision contained in the Sales Contract is declared or held invalid by a court of competent jurisdiction, such declaration or holding shall not affect the validity of any other term, clause or provision contained herein.

23. **GOVERNING LAW AND LIMITATION.** (a) The formation and performance of the Sales Contract shall be deemed to have been made and governed by the Uniform Commercial Code as adopted in the state of Seller's principal place of business; (b) Buyer hereby agrees to the jurisdiction of any state or federal court located in the county of Seller's principal place of business. Buyer waives any objection based on forum non conveniens and any objection to venue of any action instituted hereunder, and consents to the granting of such legal or equitable relief as is deemed appropriate by a court of competent jurisdiction. The rights and obligations of Seller and Buyer shall not be governed by the provisions of the United Nations Convention on Contracts for the International Sale of Goods; and (c) Seller represents that the goods will be produced in compliance with the Fair Labor Standards Act of 1938, as amended. (d) BUYER AGREES TO PAY ALL OF SELLER'S COSTS AND EXPENSES OF COLLECTION AND LITIGATION, INCLUDING BUT NOT LIMITED TO ATTORNEYS' FEES AND COSTS.

Revised 9/03